

# MODEL 310

## Programmable Timer

- Multiple Timing Ranges
- 5 Function Modes
- Digital Timing Circuit
- 5-Year Unconditional Warranty



### DESCRIPTION

The Model 310 Programmable Timer is a universal timer designed to replace over 20 standard timers. Each Model 310 can be set for one of five functions in four timing ranges, and is available in two voltage ranges.

The digital design of the Model 310 provides high accuracy repeatability and response time. The heavy-duty output relay carries loads up to 10 amps at up to 240 volts AC, resistive.

Programming is accomplished by simply installing jump-wires between two or more socket pins. An LED indicator illuminates when the relay is energized.

### PIN DIAGRAM

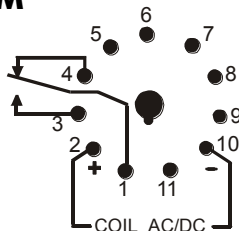

### DIMENSIONS

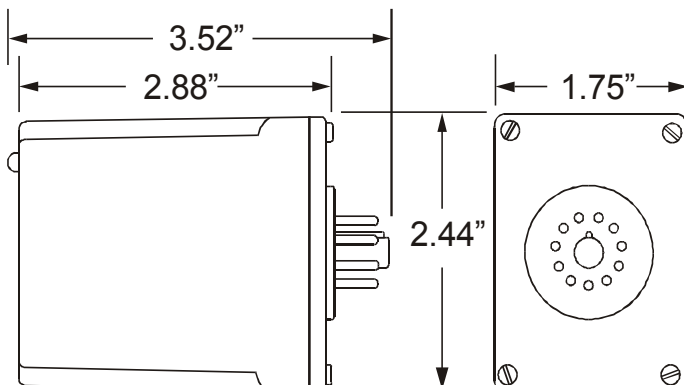

(dimensions have tolerance of  $\pm 0.06$ )

*Shows No Power Applied*

### SPECIFICATIONS

MODEL	310-24	310-120
Supply Voltage	24V AC/DC	110VDC / 120VAC
Voltage Range (AC)	20-28V 50/60Hz	105-130V 50/60Hz
Voltage Range (DC)	20-32VDC	95-125VDC
Functional Modes	Interval Timer; Operate Delay Release Delay; Single Shot; Recycle	
Timing Ranges	0.15 to 15 seconds; 0.6 to 60 seconds 5 to 480 seconds; 0.6 to 64 minutes	
Accuracy	$\pm 10\%$ **	
Repeatability	0.1% **	
Response Time	100ms **	
Power Consumption	3W	
Contact Rating	SPDT 10A at 240VAC resistive	
Expected Relay Life	Mech: 10 million operations Elec: 100,000 operations at rated load	
Operating Temp	$-4^{\circ}$ to $+122^{\circ}$ F	
** @ Ambient Temp	70° F	
Humidity Tolerance	0-97% without condensation	
Enclosure Material	ABS plastic	
Mounting	11-pin socket (not included)*	
Weight	4.5 oz.	

\* order 11-pin socket number 51 X 016

### PROGRAMMING

TIME DELAY MODES	JUMPER
Interval Timer	2 to 5
Operate Delay	2 to 5, 7 to 10
Release Delay	N.O. switch 2 to 6
Single Shot	N.O. switch 2 to 5
Recycle	2 to 5, 7 to 10 to 11
TIMING RANGE	JUMPER
0.15 to 15 seconds	9 to 10
0.6 to 60 seconds	8 to 10
5 to 480 seconds	8 to 9 to 10
0.6 to 64 minutes	none

# MODEL 310 Programmable Timer

READ ALL INSTRUCTIONS BEFORE INSTALLING, OPERATING OR SERVICING THIS DEVICE.  
KEEP THIS DATA SHEET FOR FUTURE REFERENCE.

## GENERAL SAFETY

POTENTIALLY HAZARDOUS VOLTAGES ARE PRESENT AT THE TERMINALS OF THE MODEL 310.

All electrical power should be removed when connecting or disconnecting wiring.  
This timer and wiring should be installed and serviced by qualified personnel.

## Installation Instructions

### INSTALLATION

Mount the 11-pin socket in a suitable enclosure. Connect the appropriate operating power to terminals 10 and 2.

Referring to the diagrams below, and the PROGRAMMING TABLE and PIN DRAWING on the reverse of this sheet, connect timing and function jumpers to the socket terminals.

Connect the load to the appropriate relay output terminals of the socket.

Install the timer in the socket.

### FUNCTION DESCRIPTIONS

**INTERVAL TIMER:** The output relay energizes when operating power is applied. When the timing period elapses, the relay de-energizes. The timer is reset by removing and reapplying power. ↓

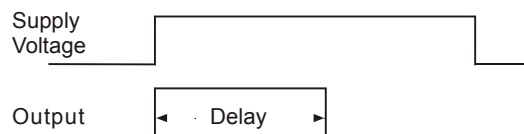

**OPERATE DELAY:** The delay period begins when operating power is applied. When the timing period elapses, the output relay energizes. The timer is reset and restarted by removing and reapplying power. ↓

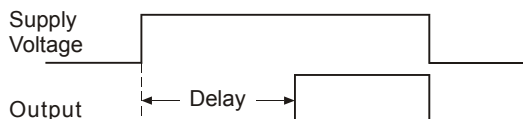

**RELEASE DELAY:** Operating power is continuously applied to the timer. When the external control switch is closed the output relay energizes. When the control switch is opened the timing period begins. If the control switch closes before the timing period elapses, the output relay remains energized and the timing period is reset. When the timing period elapses, the output relay de-energizes. The timer is restarted by re-closing the control switch. → *Refer to diagram at top of next column*

*This diagram refers to RELEASE DELAY function (previous column)*

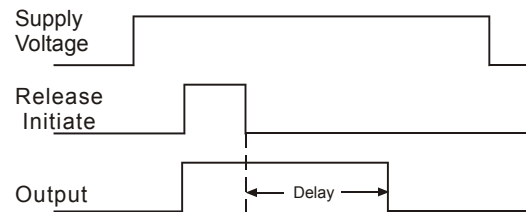

**SINGLE SHOT:** Operating power is continuously applied to the timer. When the external control switch is closed the output relay energizes and the timing period begins. Regardless of the condition of the control switch, when the timing period elapses the output relay de-energizes. ↓

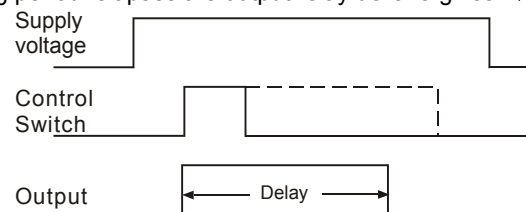

\* If Switch is re-closed before time has elapsed, timing will restart\*

**RECYCLE:** Operating power is continuously applied to the timer. When operating power is applied, the OFF delay period begins. When the OFF delay period elapses, the output relay energizes, and the ON delay period begins. This cycle repeats until operating power is removed. ↓

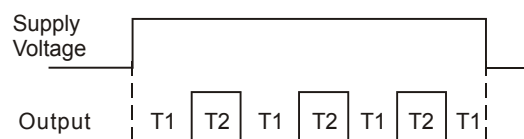

**NOTE:** For recycle timing ON and OFF times are equal.

### WARRANTY

This product is warranted to be free from defects in materials and workmanship, and is covered by our exclusive **5-year Unconditional Warranty**. Should this device fail to operate for any reason, we will repair it for five years from the date of manufacture. For complete warranty details, see the *Terms and Conditions of Sales* page in the front section of the Time Mark catalog or contact Time Mark at 1-800-862-2875.